

THUNDERSTRUCK™
AG EQUIPMENT

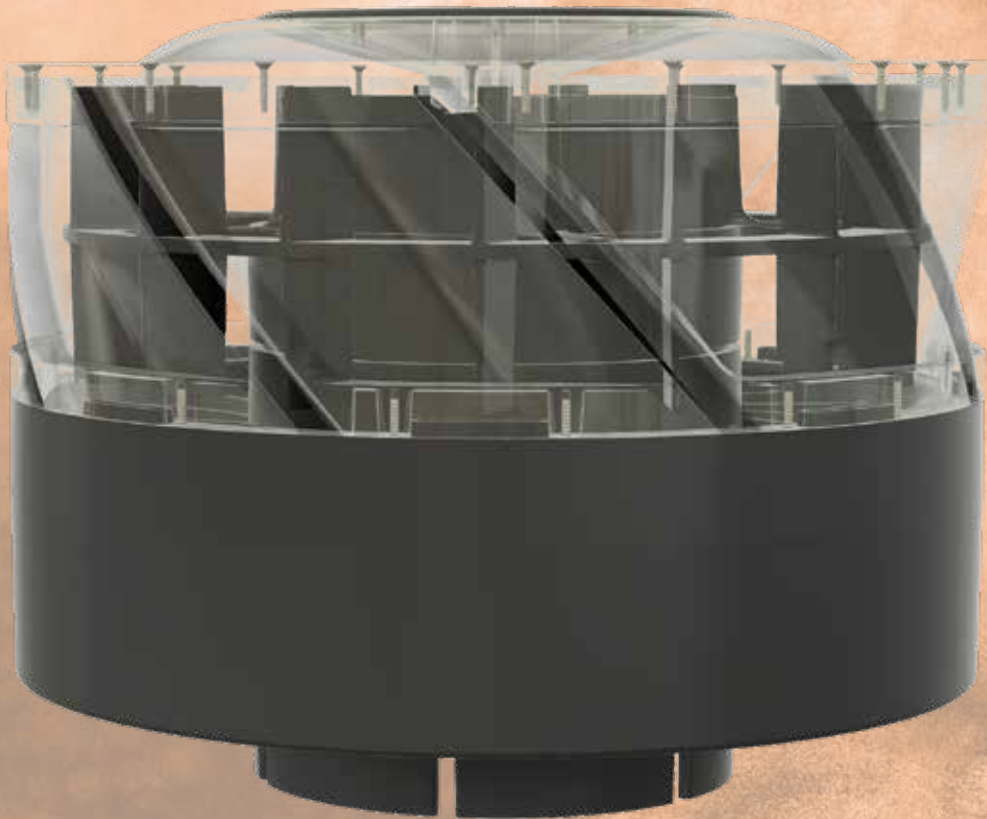

REDEKOP KAS

KAS PRE-CLEANER
CR 90X0, 7000, 8000
CR ADAPTER KIT



INSTALLATION MANUAL

Safety

Instructions

IMPORTANT: Read through this installation manual thoroughly and familiarize yourself with the KAS Pre-cleaner before installation of these components.

This installation manual explains the proper procedure for installation of the KAS Pre-cleaner. Do not skip steps or perform them out of order.



Recognize Safety Information

This is a safety-alert symbol. When you see this symbol on your straw chopper or in this manual, be alert to the potential for personal injury.

Follow recommended precautions and safe operating practices.



Understand Signal Words

A signal word - DANGER, WARNING, or CAUTION - is used with the safety-alert symbol. DANGER identifies the most serious hazards.

WARNING or CAUTION safety signs are located near specific hazards or precautionary areas in this manual.



Work In Ventilated Area

Engine exhaust fumes can cause sickness or death. If it is necessary to run an engine in an enclosed area, remove the exhaust fumes from the area with an exhaust pipe extension.

If you do not have an exhaust pipe extension, open the doors and get outside air into the area.



Remove Key from Ignition

ALWAYS shut off machine engine prior to working on it.

Apply park brake, remove key and lock operators cab.

If the machine is equipped with an additional safety master power switch, turn this to the Power OFF position.

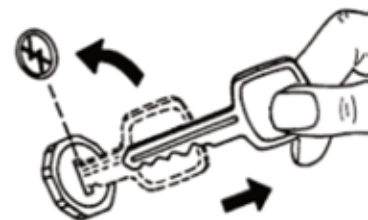

Block Wheels

Park the machine on level ground.

Always engage the park brake and block the wheels prior to working to prevent the machine from moving.



Practice Safe Maintenance

Understand service procedure before doing work. Keep area clean and dry.

Never lubricate, service, or adjust machine while it is moving. Keep hands, feet and clothing away from power-driven parts. Disengage all power and operate controls to relieve pressure. Lower equipment to the ground. Stop the engine. Remove the key. Allow machine to cool.

Securely support any machine elements that must be raised for service work.

Keep all parts in good condition and properly installed. Fix damage immediately. Replace worn or broken parts. Remove any buildup of grease, oil or debris.



Guards and Shields

Keep guards and shields in place at all times. Ensure that they are serviceable and maintained correctly.



Avoid Contact With Moving Parts

Keep hands, feet and clothing away from power driven parts. Never clean, lubricate or adjust machine when it is running.

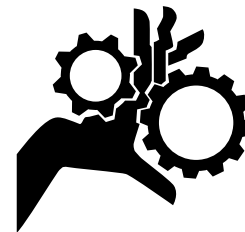

Dispose of Waste Properly

Improperly disposing of waste can threaten the environment and ecology. Potentially harmful waste includes such items as oil, fuel, coolant, brake fluid, filters and batteries.

Use leakproof containers when draining fluids. Do not use food or beverage containers that may mislead someone into drinking from them.

Do not pour waste onto the ground, down a drain or into any water source.



Personal Protective Equipment (PPE)

A qualified person designated by the employer, who is knowledgeable about and familiar with all relevant specifications and assembly instructions and is capable of identifying existing or potential hazards in surroundings or working conditions which may be hazardous or dangerous to employees shall determine appropriate Personal Protective Equipment required for this assembly.

Personal Protective Equipment (PPE) are devices worn by the employees to protect against hazards in the environment. Examples include safety glasses, face shields, respirators, gloves, hard hats, steel-toe shoes, and hearing protection. Wear close fitting clothing and safety equipment appropriate for the job.

Operating equipment safely requires the full attention of the operator. Do not wear music headphones while operating machine.

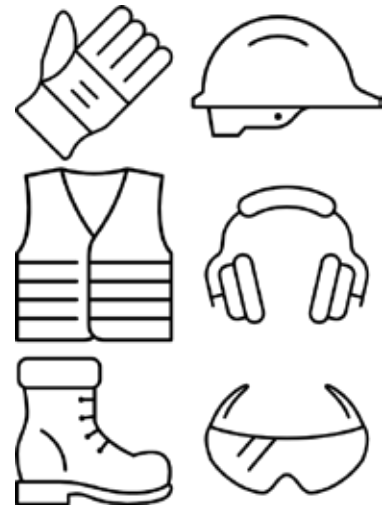

Prepare for Emergencies

Be prepared if a fire starts.

Keep a first aid kit and fire extinguisher handy.

Keep emergency numbers for doctors, ambulance service, hospital and fire department near your telephone.



In the Event of Fire

Stop work immediately at first sign of fire. This may be the smell of smoke or the sight of smoke or flames. Get off the machine immediately and move away from the fire. Do not return to the machine or fire!



CAUTION: Avoid personal injury.
If a fire is too far advanced, do not try to extinguish it. Call the fire department!
The number one priority is safety. Always put the safety of the operator and bystanders first.
If a fire can be safely extinguished, proceed carefully and follow these guidelines:

1. Remove fire extinguisher from bracket and carry it to the area of fire.
2. Approach area of fire with your back to the wind.
3. Pull the safety pin out of actuating lever.
4. Hold extinguisher upright, pointing nozzle away from you and aim hose at base of the flames.
5. Squeeze the lever slowly and evenly to discharge fire extinguisher.
6. Move extinguisher nozzle side to side to cover the source of the fire evenly with extinguishing agent.



Safety Decals

Pictorial Safety Signs

At several important places on this machine, safety signs are affixed intending to signify potential danger. The hazard is identified by a pictorial in a warning triangle. An adjacent pictorial provides information on how to avoid personal injury. These safety signs and a brief explanatory text follow.

Hand Injury / Rotate Danger RP1089

Risk of injury caused by rotating parts.

Caution / Check Service Manual RP873

This operator's manual contains all important information necessary for safe machine operation. Carefully observe all safety rules to avoid accidents.



ADAPTOR KIT INSTALLATION

This kit is for OEM low mount air cleaner with this configuration:



Installed low mount KAS adaptor and KAS Pre-cleaner kit:

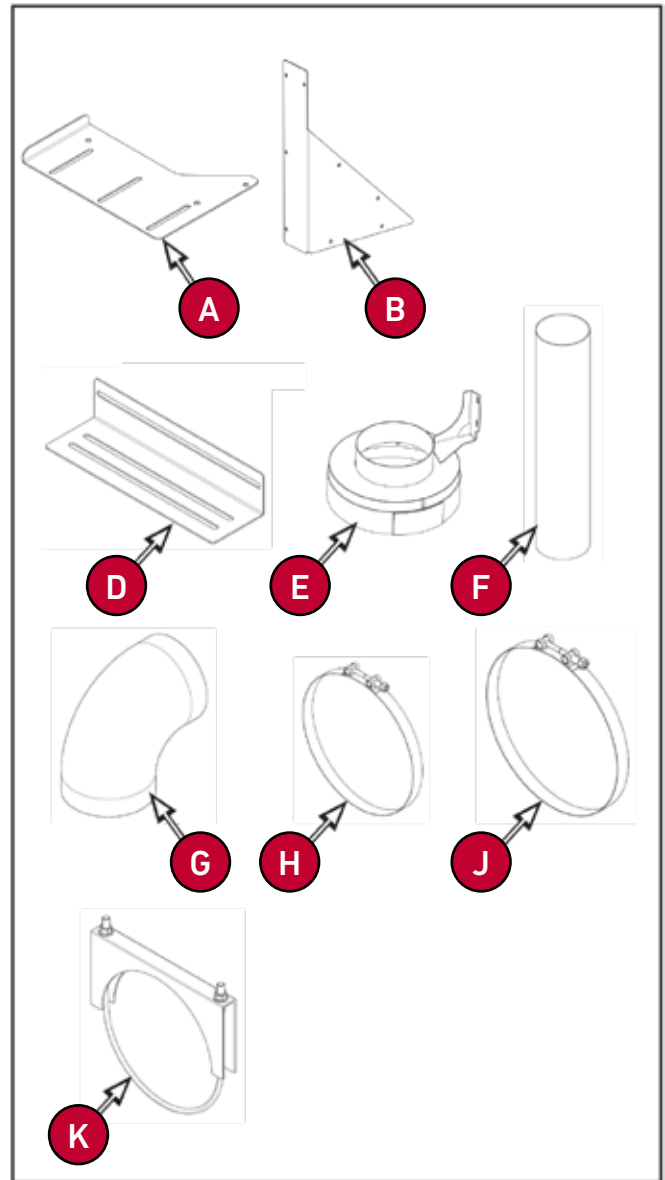

Parts List:

KA124B Tubing Support Plate (A)	Qty 1
KA123B Radiator Blank Off Plate - Wrap Around (B)	Qty 1
KA114B Support Bracket (D)	Qty 1
KA127BA Adapter Assembly - 13 to 8 (E)	Qty 1
KA111BAir Intake Tube (F)	Qty 1
RP1563 Elbow 90 Deg EPDM - 8" ID (G)	Qty 1
RP1564 Clamp T-Bolt 0.25 x 8.88 ID SS (H)	Qty 2
RP1565 Clamp T-Bolt 0.25 x 13.5 ID SS (J)	Qty 1
RP1561 Clamp UBolt - 8-1/8" ID (K)	Qty 1

ADAPTOR KIT INSTALLATION



1. Remove OEM intake elbow (**M**) from radiator box (**N**) - hardware (**M1**) to be reused

2. Remove OEM intake elbow (**M**) from filter housing (**P**) - Hose clamp (**R**) to be reused



3. Clean surface of filter housing (**P**)
- Ensure all tubes/openings (**P1**) are clear of debris and clean



4. Remove OEM top plate mounting hardware (**N1**) x3 from radiator box (**N**)
- Hardware (**N1**) to be reused



** Ensure dust, dirt and chaff is blown away from work area **

** Ensure no debris enters engine intake while transition chute is removed **

ADAPTOR KIT INSTALLATION

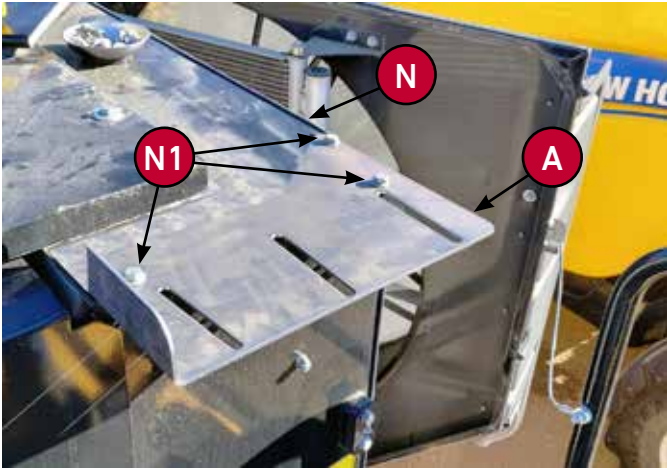

5. Install tubing support plate (A) to top of radiator box (N), with:
- Reuse hardware (N1) x3

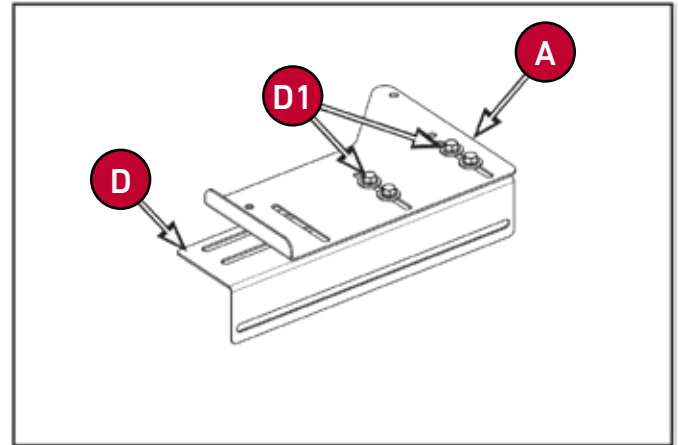

6. Install support bracket (D) to underside of tubing support plate (A), with:
- M8 x 20 flange head bolt, flat washer and flange nut (D1) x4



7. Install radiator block off plate (B) to lower corner radiator box (N), with:
- Reuse M6 hardware (B1) x8
- New M6 flange nut (B1) x8

ADAPTOR KIT INSTALLATION

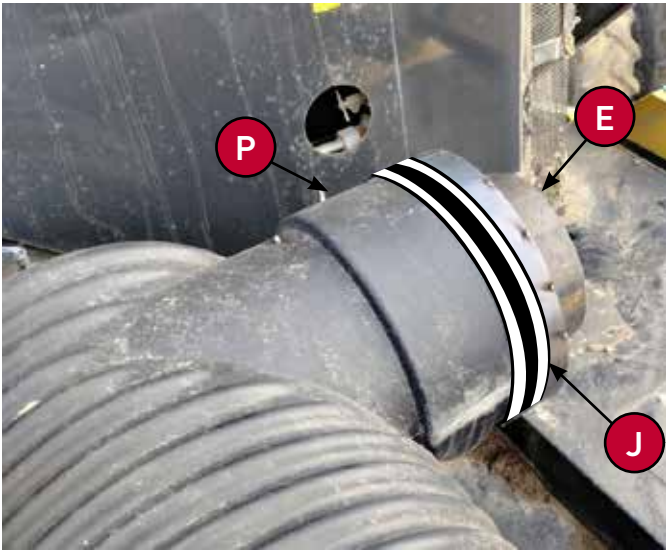

8. Install adaptor (E) to filter housing (P)

9. Secure adaptor (E) in place, with:

- Hose clamp (J) x2
- Ensure the rubber strap (E1) overlaps adaptor and housing
- Ensure this is a tight fit and there are no air leaks around adaptor

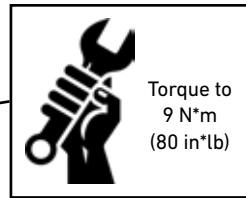

Torque to
9 N*m
(80 in*lb)

Torque to 9 N*m (80 in-lbs)

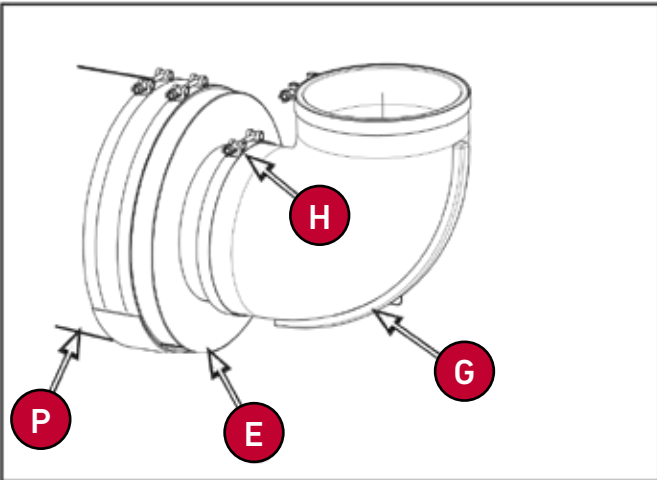

10. Install rubber elbow (G) to adaptor (E), with:

- Hose clamp (H)
- Spray lubricant may be required

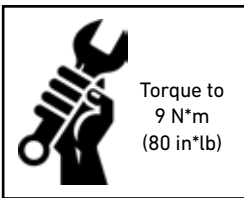

Torque to
9 N*m
(80 in*lb)

Torque to 9 N*m (80 in-lbs)

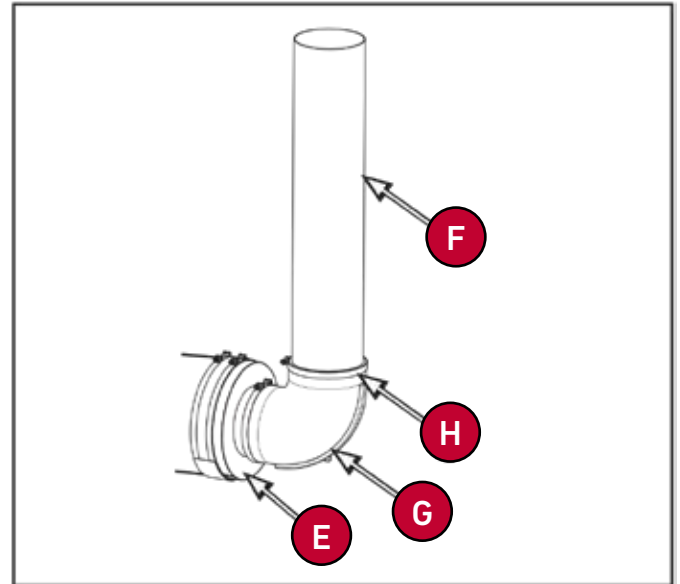

11. Install air intake tube (F) to elbow (G), with:

- Hose clamp (H)
- Spray lubricant may be required

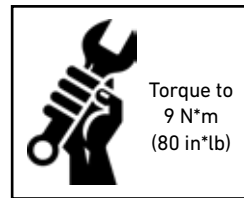

Torque to
9 N*m
(80 in*lb)

Torque to 9 N*m (80 in-lbs)

ADAPTOR KIT INSTALLATION

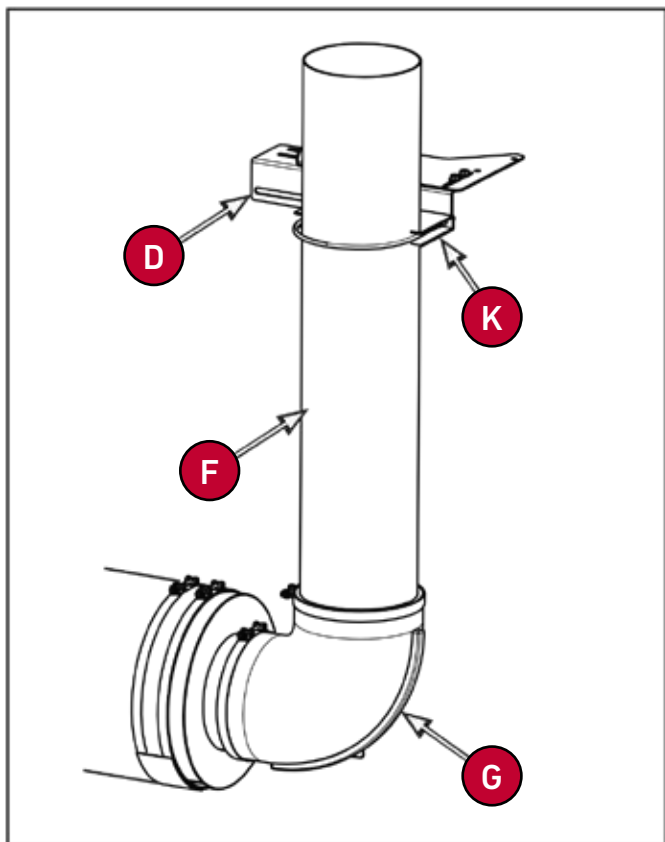

12. Install hose clamp (**K**) around air intake tube (**F**) and secure to support bracket (**D**)

13. Align air intake tube (**F**) so that it is straight and centered

14. Tighten all hardware

15. If equipped with the KAS Pre-cleaner, see section 2 of complete installation

KAS PRE-CLEANER INSTALLATION

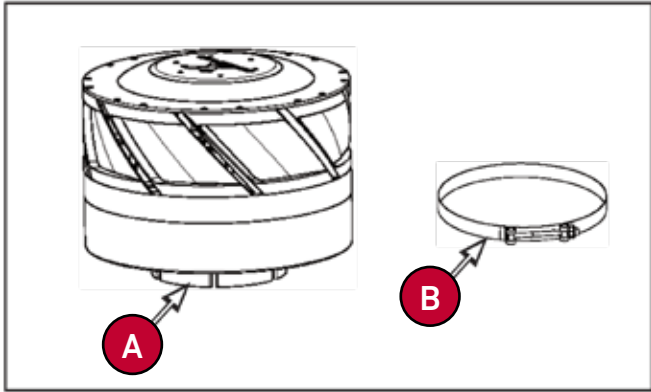

Parts List:

- KA800A KAS Pre-cleaner Assembly 8in (A) Qty 1
- RP1535 Clamp T-Bolt Band 0.25 x 8.5 ID SS (B) Qty 1



1. Install KAS pre-cleaner assembly (A) on to adapter tube (C), with:
- Hose clamp (B)

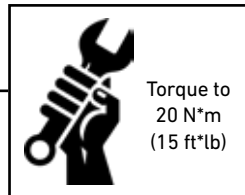

Torque to 20 N*m (15 ft-lbs)



CAUTION

When the grain tank extensions and the auger are folded down, the KAS Pre-cleaner will be the tallest point on the combine

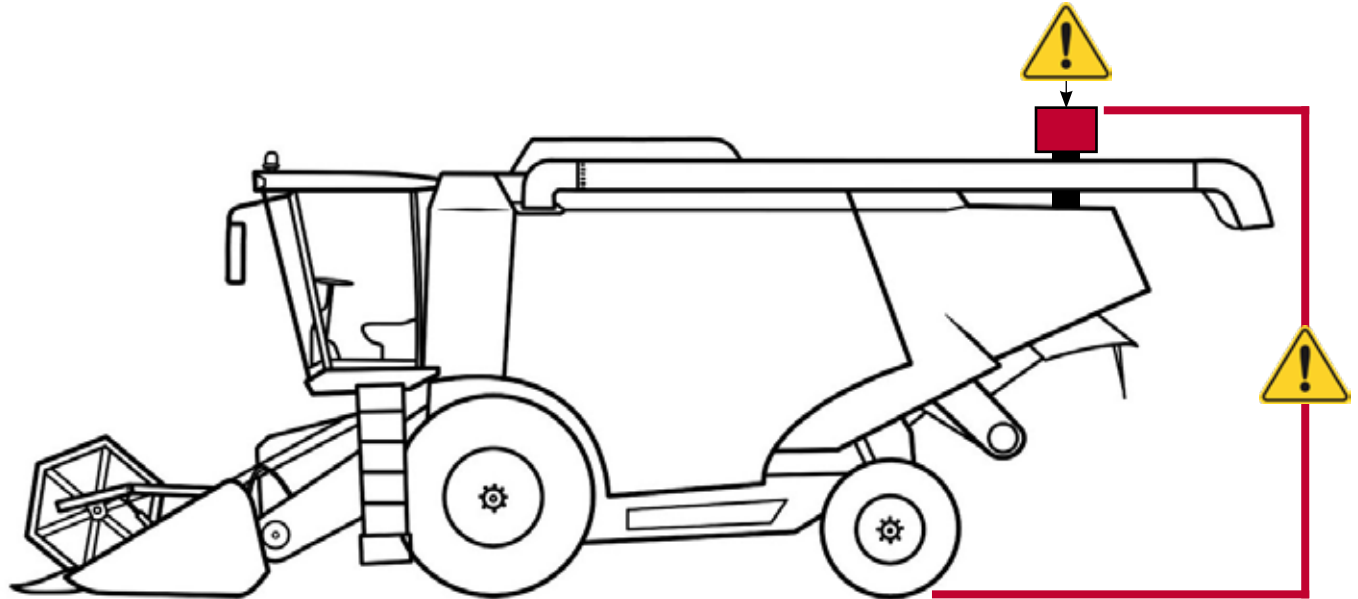

TORQUE TABLE

Normal Size	Class 8.8	Class 10.9
	Nm/(ft-lbs)	Nm/(ft-lbs)
M8		
Flanged	27/(20)	39/(29)
Non-Flanged	25/(18)	35/(26)
M10		
Flanged	54/(40)	57/(42)
Non-Flanged	49/(36)	70/(51)
M12		
Flanged	93/(69)	134/(90)
Non-Flanged	85/(63)	121/(90)



Check all fasteners to ensure they have been properly tightened

Check that all tools and loose hardware have been removed from the machine before running

Manufacturer's Warranty:

Limited Warranty Statement Redekop Manufacturing (2014), hereinafter referred to as "Manufacturer", warrants each new Redekop Straw Chopper sold by the Manufacturer to be free from defects in material and workmanship, under normal use and service, for a period of one (1) year after the date of delivery to the original retail purchaser. The Manufacturer will, at its option, replace or repair, at the Manufacturer's factory, or at a point designated by the Manufacturer, any part or parts which shall appear to the satisfaction of the Manufacturer upon inspection at such point, to have been defective in material or workmanship. This Warranty does not obligate the Manufacturer to bear any transportation charges in connection with the replacement of defective parts.

This Warranty shall not apply to any upgrade which shall have been installed or operated in a manner not recommended by the Manufacturer; nor to any upgrade which shall have been repaired, altered, neglected or used in any way which, in the Manufacturer's opinion, adversely affects its performance; nor to any upgrade in which parts not manufactured or approved by the Manufacturer have been used; nor to any accessories installed on the upgrade where the accessory manufacturer has its warranty; nor to normal maintenance or replacement of normal service items.

Manufacturer reserves the right to modify, alter, and improve any upgrade or parts without incurring any obligation to replace any upgrade or parts previously sold with such modified, altered or improved upgrade or part.

THIS WARRANTY, AND THE MANUFACTURER'S OBLIGATION HEREUNDER, IS IN LIEU OF ALL OTHER WARRANTIES, EXPRESSED, IMPLIED, OR OF FITNESS FOR A PARTICULAR PURPOSE, and all other obligations or liabilities, including special or consequential damages or contingent liabilities arising out of the failure of any upgrade or part to operate properly. No person is authorized to give any other warranty or to assume any additional obligation on the Manufacturer's behalf unless made in writing and signed by an officer of the Manufacturer. This Warranty is effective only for the original purchaser. Redekop Manufacturing 2014 Saskatoon, SK Canada

Warranty with the dealer:

Thunderstruck Ag Equipment is a distributor of the products we sell and does not provide any direct warranty coverage. All warranty claims and coverage are provided solely by the product's manufacturer, according to their specific terms and conditions.

If you experience a product issue and believe it may be covered under warranty, please contact one of our sales representatives. We're happy to assist you in coordinating your claim with the appropriate manufacturer.